





SHARP

XG-MB70X
True XGA Multimedia Projector

Rear Terminals

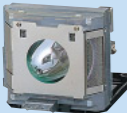

Optional Accessories

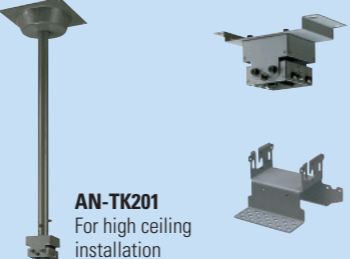
Lamp  AN-MB70LP	Adaptor  AN-A1RS DIN-D-sub RS-232C adaptor (15 cm)	Cable  AN-C3CP2 3-RCA to 15-pin D-sub cable (3 m)	Ceiling Mounts  AN-TK201 For high ceiling installation AN-TK202 For standard ceiling installation AN-60TK Installation adaptor
--	--	---	---

Note: Some of the optional accessories may not be available depending on the region. Please check with your nearest Sharp Authorized Projector Dealer or Service Center.

Specifications

Model	XG-MB70X
Panels	0.7" DMD
Number of pixels	786,432 dots (1,024 x 768; h x v)
Resolution	550 TV lines (video input), 750 TV lines (DTV 720P input)
Video/data systems	RGB input signals: SXGA+, SXGA, Mac 21" (in intelligent compression), XGA, SVGA, VGA, VESA, Mac 19"/16"/13", 15-70 kHz (horizontal), 43-85 Hz (vertical), 12-108 MHz (pixel clock) (plug & play VESA: DDC 1/2/8) Video colour systems: NTSC/NTSC 4.43/PAL/PAL (60Hz)/PAL-M/PAL-N/SECAM/ DTV [480I/480P/540P/580I/580P/720P/1035I/1080I(50Hz/60Hz)]
Lens	1:1.5 zoom and auto focus with iris
Projection size	40" (102 cm) to 300" (762 cm)
Projection distance	40" (102 cm): 1.2 – 1.8m, 100" (254 cm): 3.0m – 4.6m, 300" (762 cm): 9.1 – 13.7m
Luminance	3,000 ANSI lumen in High Brightness Mode (Standard Mode) / 2,600 ANSI lumen in High Brightness Mode (Eco Mode)
Contrast ratio	2000:1 (High contrast mode)
Audio amplifier	2W (mono)
Speakers	4 x 2.85cm (oval) x 1
Input terminals	Computer RGB component x 2 (15-pin mini D-sub), video x 1 (RCA), S-video x 1, audio L/R x 1 (3.5 mm mini jack), RS-232C serial x 1 (9-pin mini DIN), LAN x 1 (RJ-45), USB x 1
Output terminals	Computer RGB / component x 1 (15-pin mini D-sub), audio L/R x 1 (3.5mm stereo mini jack)
Power source	100-240V AC, 50/60 Hz (Multi-Voltage)
Power consumption	370W (Standard Mode), 320W (Eco Mode), 6W (Standby) with AC 100V 350W (Standard Mode), 300W (Eco Mode), 8W (Standby) with AC 240V
Heat dissipation	1,390 BTU/hour (Standard Mode), 1,200 BTU/hour (Eco Mode) with AC 100V 1,315 BTU/hour (Standard Mode), 1,130 BTU/hour (Eco Mode) with AC 240V
Fan noise	35 dB (Standard Mode), 32 dB (Eco Mode)
Projection lamp	275W
Lamp life*1	2,000 hours (Standard Mode) / 3,000 hours (Eco Mode)
Dimensions (W x H x D)	310 x 89 x 282 mm (main body only), 310 x 104 x 287 mm (including adjuster legs and lens)
Weight	4.1 kg

Design and specifications are current as of September 2004, but are subject to change without notice.

* Digital Light Processing, DLP and the DLP medallion are trademarks of Texas Instruments.

* All company and/or product names are trademarks and/or registered trademarks of their respective manufacturers.

Sharp makes no warranties of representations of any kind with respect to these products.

*1 The lamp life may vary depending on the usage condition.



Pixelworks ICs are used in this projector.

High-Brightness, High-Contrast, High-Performance DLP Projector with Slim Body and Superb Dust Resistance



SHARP
SHARP CORPORATION OSAKA, JAPAN
URL <http://www.sharp-world.com/>



* The projected light is a simulated image.

Slim-Bodied, High-Performance DLP Projector Expands Application Possibilities Ranging from Business to Education

Cutting-Edge DLP Technology Provides All-Around Advantages in its Performance

The XG-MB70X employs a DLP™ system for the display device that controls the DMD™ (Digital Micromirror Device) chip, which contains many thousands of micromirrors on the silicon chip, reflecting light to display images.

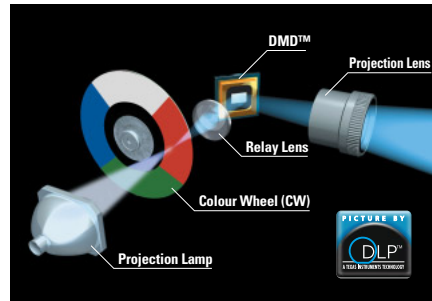

Slim, Lightweight and Compact Design

With the DLP™ system, the XG-MB70X presents a slim (89 mm) body without hindering presentations, helping your business with numerous applications.

3000 ANSI Lumen High Brightness

Sharp's advanced optoelectronics technology maximizes light output, providing excellent uniformity and amazingly high brightness in this size of projector.

2000:1 High Contrast for Big Screen Projection

The DLP™ optical system prevents light leakage compared with LCD projection and provides sharper blacks in black parts and a 2000:1 high contrast ratio as well as employing an iris developed in Sharp theatre projectors.

The XG-MB70X is thus ideal for large-screen theatre projection, providing high-quality pictures for DVD*, HDTV and education videos. It is also compatible with worldwide broadcast signals such as NTSC, PAL and SECAM.

* A separate DVD player is needed for viewing DVDs.

Sealed Optics

The optical mechanism of DLP™ system projectors is sealed in its structure, preventing dust, dirt and smoke from the entering core parts of the optics to a much greater degree than with LCD projectors. The system also needs no filter and less maintenance, resulting in lower cost of ownership and longer use.

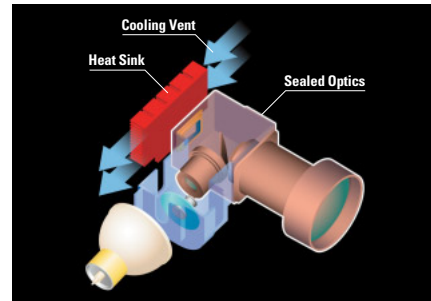

Long-life High-Performance DMD™ Panel

DMD™ silicon chip formation with finely structured mirrors provides stable performance and delivers high-quality pictures for longer periods. The DMD™ chip in the XG-MB70X achieves a lifetime of 20,000 hours*.

Also, because there is no burn-in or remaining afterimage, the XG-MB70X is ideal for still picture projection such as for guidance board applications and projecting CAD images.

* The lifespan is measured at the surrounding temperature of 25°C. This is a reference value and is not guaranteed.

And More Advantages

The projector provides better compensation of picture uniformity.

3x Speed Colour Wheel

The XG-MB70X employs a primary colour wheel with a 3x speed engine, providing much shorter projection time and thus improving colour break-up to an invisible level.

Improved Projection Performance

Auto Focus and Power Zoom Lens

The XG-MB70X employs auto focus and a power zoom lens, eliminating the hassle of adjusting the picture on the screen. You can start presentations quickly and comfortably.



Short Throw Lens (Optical 1.5X Zoom Lens)

The newly developed Short Throw Lens achieves 60-inch large screen projection even from the short distance of 1.8m. In addition, the projector can be mounted more flexibly with the 1.5x zoom lens.

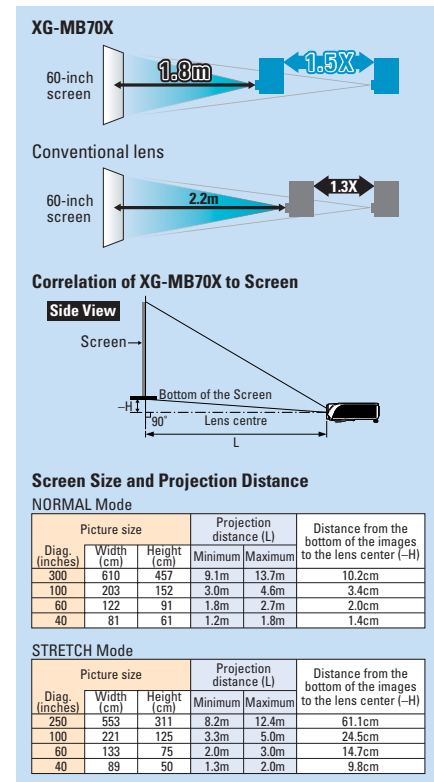

Network Possibilities

LAN Connection

Incorporating terminals for LAN connection as standard features, the XG-MB70X enables turning the power on or off and switching inputs without using special software. It is also possible on a network to monitor and control projectors for overall execution.

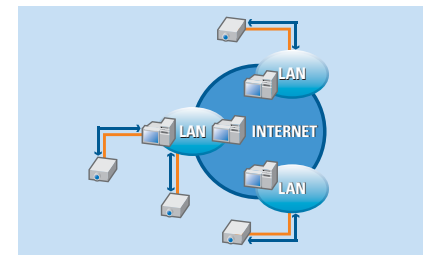

Remote Access and Management

Newly developed web browser control* enables remote access and management of the projector without special software. In addition, it sends e-mail to a maximum of five appointed addresses when detecting something wrong such as the lamp going out, unusual heating or cooling fan breakdown.

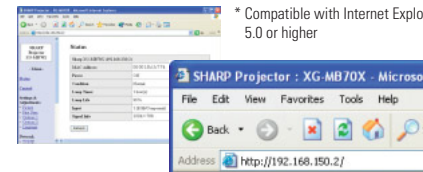

Smooth Presentation Even for Beginners

Intuitive Layout of Buttons and Terminal Layout

For intuitive button layout, essential and frequently used buttons for basic operations, setup and image adjustment are located close together. This layout allows simple setup and operation for anybody. And, a wide variety of AV/PC terminals are effectively placed with colour guidance.

Remote Control with Mouse

Screen displaying presentation software such as PowerPoint® can be easily moved forward/backward and the cursor can be moved by remote control.



Quick Guide

Any person first using the XG-MB70X can quickly set up and use it with just a quick glance at the reference sticker enclosed. Placing the sticker close to operation buttons simplifies basic operation by eliminating the need to check operation manuals.

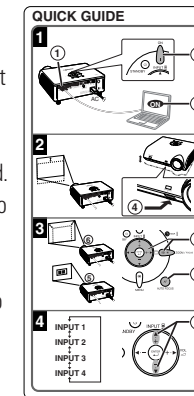

Security & Safety

Notevision Lock-Down Function

The optical unit provides a solid mounting point for ceiling mount hardware, and the joint area is reinforced by a metal plate. This achieves a maximum loading capacity of 5,700N*. Static Load Capacity on the XG-MB70X: Maximum 5,700N (equivalent to a 580kg object hung on the projector) (When hanging with four mounting points)

* N (Newton) is the unit for force. When hanging a 1-kg object to the ceiling mounted projector, the projector is subjected to a force equivalent to 10N. (Based on Sharp load test)

Other Outstanding Features

- 32dB Low Noise Level in Eco Mode
- True XGA Compatibility/SXGA+ (1,400 x 1,050) compatible in intelligent compression
- sRGB Compatibility
- Auto Response Adjust (ARA)
- Digital Keystone Correction compensates for picture distortion
- Simple Key Lock and System Lock Function
- Enlarge & Freeze
- Storage Case

Dimensional Drawings

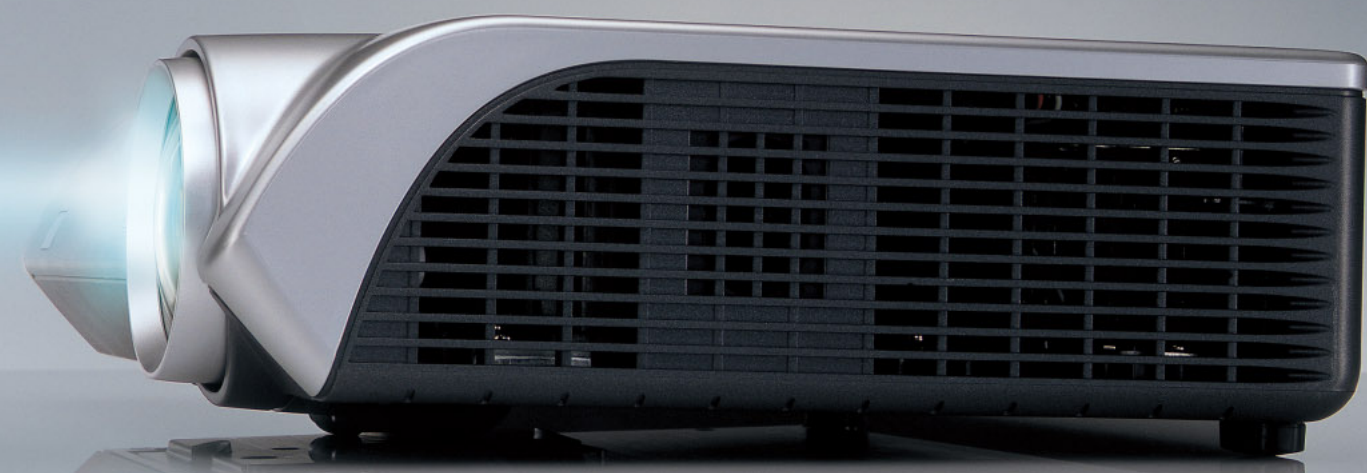
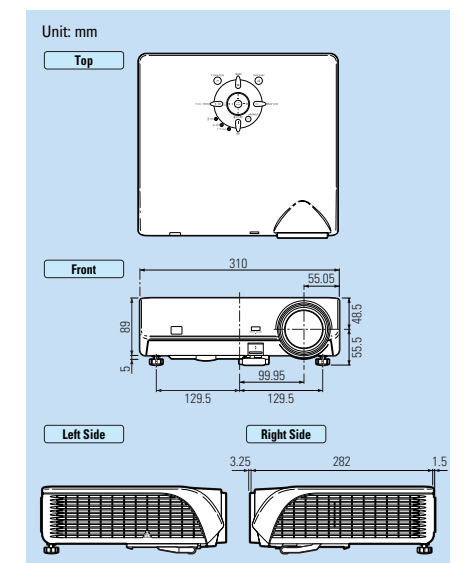

* The projected light is a simulated image.